

CHEMICAL PUMPS SINCE 1992

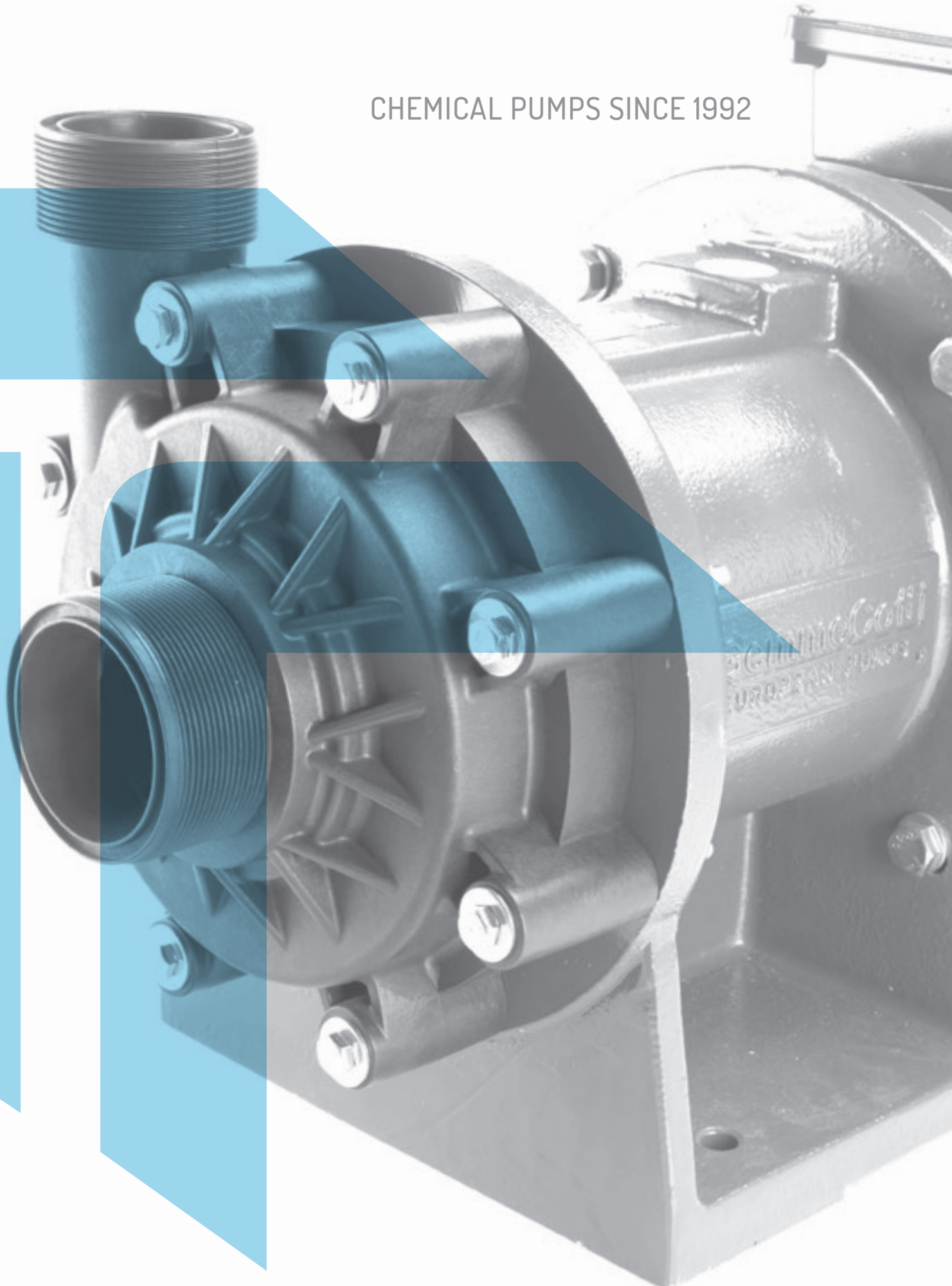

# ATEX PUMPS



For pumping applications in potentially explosive atmospheres GemmeCotti offers ATEX certified pumps suitable for zone 1 II 2G c Tx and zone 2 II 3G c Tx.

## The ATEX pumps available are:

Pumps model EM-C / EM-T / EM-P in PP or PVDF - only for ATEX zone 2 (See pumps model HTM PP/PVDF page 12, HTT page 26 and HPP/HPF page 34)

All our ATEX pumps comply with the technical and safety requirements of ATEX directive 2014/34/EU.

Pump model EM-C in AISI316 - for ATEX zone 1 and 2 (See pump model HTM SS316 page 20)



Pump model EM-T in AISI 316 - for ATEX zone 1 and 2 (See pump model HTA page 30)

Pump model EM-P in AISI 316 for ATEX zone 1 and 2 (See pump model HTP page 36)



# HTM SS 316

## METALLIC MAG-DRIVE CENTRIFUGAL PUMPS



### MAIN FEATURES

Mag drive centrifugal pumps series HTM SS are made of AISI 316 or, on request, of other metallic materials (such as HASTELLOY or TITANIUM) and are suitable for hydrocarbons, solvents and dangerous liquids. Thanks to the innovative mag drive design, pumps model HTM SS reduce the risks of leakage and emissions and the maintenance costs. The transmission of the motion occurs through magnetic joints without any mechanical seal. This design guarantees the maximum safety and efficiency. The pumped liquid has to be clean and without solids in suspension. Pumps series HTM SS 316 are also available in ATEX version for zone 1 and 2 (pump model EM-C).

### STANDARD:

- Threaded in and out connections.

### OPTIONAL:

- Pump available in other materials (HC 276; Titanium).
- ATEX version (pumps mod. EM-C).
- Explosion proof motor.
- Flanges available.
- Dry-running protection.
- Baseplate.
- Overload switch.

- Materials available: AISI 316;
- Materials in contact with the liquid: casing and impeller: stainless steel AISI 316; o-ring: EPDM/VITON; bushing: PTFE/CARBON; shaft: Hastelloy C276.
- Max flow: 32 m<sup>3</sup>/h; max head: 24 mlc.
- Max temperature: 160° C.
- Max viscosity: 200 cSt.
- Pressure rating: NP 10 at 20° C.

## PERFORMANCE CURVES 50HZ - 2900 RPM

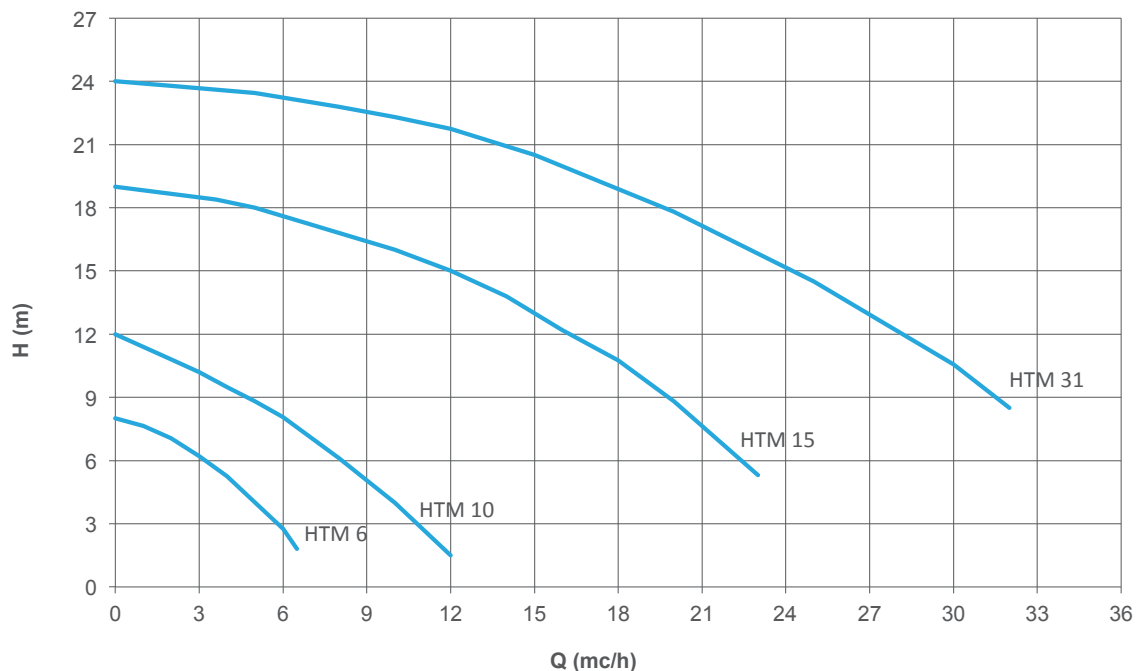

### HTM SS 316 TECHNICAL DATA

PUMP SIZE	MATERIAL	Q MAX		H MAX		SUCTION CONNECTION	DISCHARGE CONNECTION	PUMP WEIGHT (KG)	SUITABLE MOTOR POWER (KW) 2900 rpm / FLANGE AND FRAME
		50HZ (M3/H)	60HZ (USGPM)	50HZ (MLC)	60HZ (FT)				
HTM 6	AISI316	6	30	8	42	1" FEMALE	3/4" MALE	6.2	0,55 / 71 B - B3/B5
HTM 10	AISI316	12	50	12	52	1 1/2" FEMALE	1" MALE	11.7	1,1 / 80 B - B3/B5
HTM 15	AISI316	23	117	19	85	2" MALE	1 1/2" MALE	17	1,5 / 90 S - B3/B5
HTM 31	AISI316	32	180	24	110	2 1/2" MALE	2" MALE	20	2,2 / 90 L - B3/B5

### HTM 6-10 SS316 • EM-C 6-10 SS316 (ATEX VERSION) DIMENSIONS

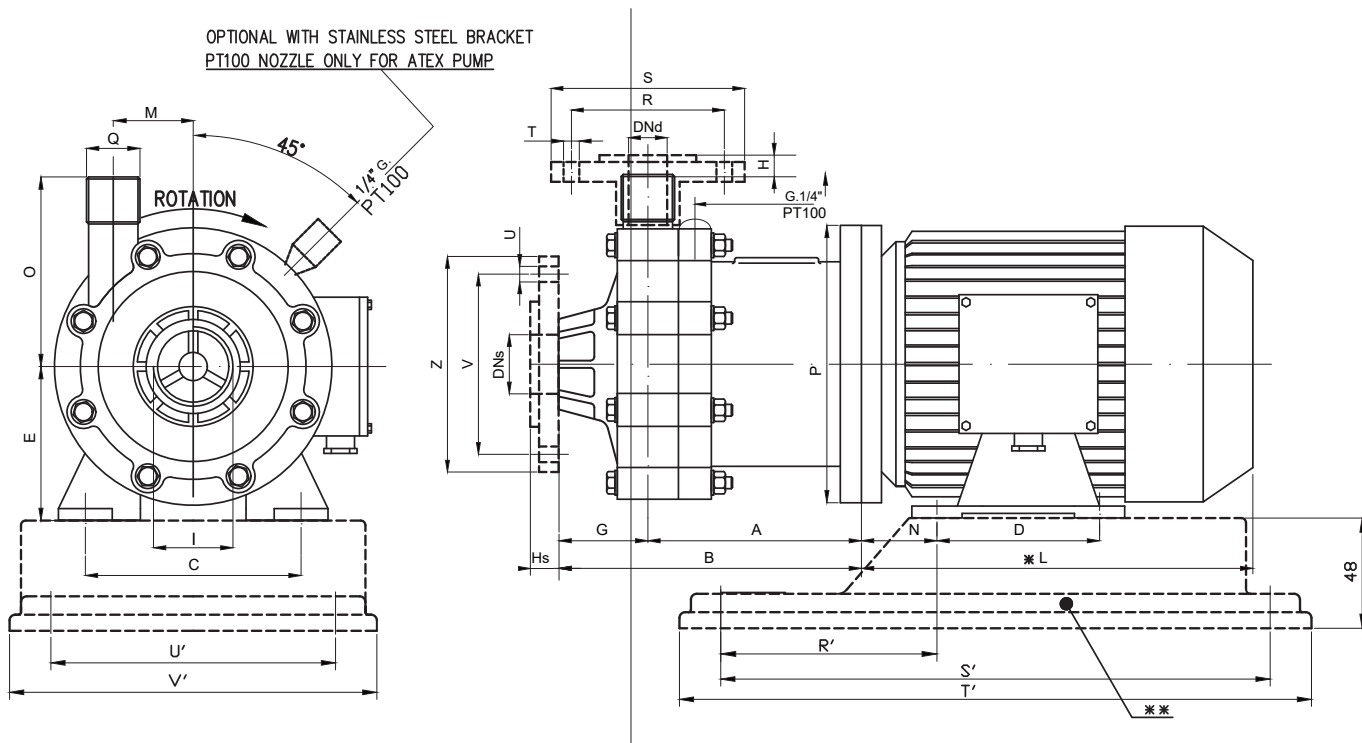

PUMP TYPE	FLANGES DIMENSIONS - mm -							
	R	S	T	U	V	Z	DN <sub>f</sub>	DN <sub>d</sub>
HTM 6 SS316	75	105	14	14	85	115	25	20
HTM 10 SS316	85	115	14	18	110	150	40	25

PUMP TYPE	MOTOR FLANGE B3 - B5	KW	DIMENSIONS - mm -														BASEPLATE DIMENSIONS - mm -					
			A	B	C	D	E	F	G	H	I	L	M	N	O	P	Q	R'	S'	T'	U'	V'
HTM 6 SS316	71 B	0,55	137	194	112	90	71	24	57	4	1" FEMALE	215	46	45	89	160	3/4" MALE	102	244	280	130	160
HTM 10 SS316	80 B	1,1	145	214	125	100	80	20	69	8	1 1/2" FEMALE	232	44	50	98	200	1" MALE	120	302	350	157	205

NOTE: DIRECTION OF ROTATION IS COUNTER CLOCKWISE AS SEEN WHEN FACING THE MOTOR. PUMPS AVAILABLE THREADED OR FLANGED.

## HTM 15-31 SS316 • EM-C 15-31 SS316 (ATEX VERSION) DIMENSIONS

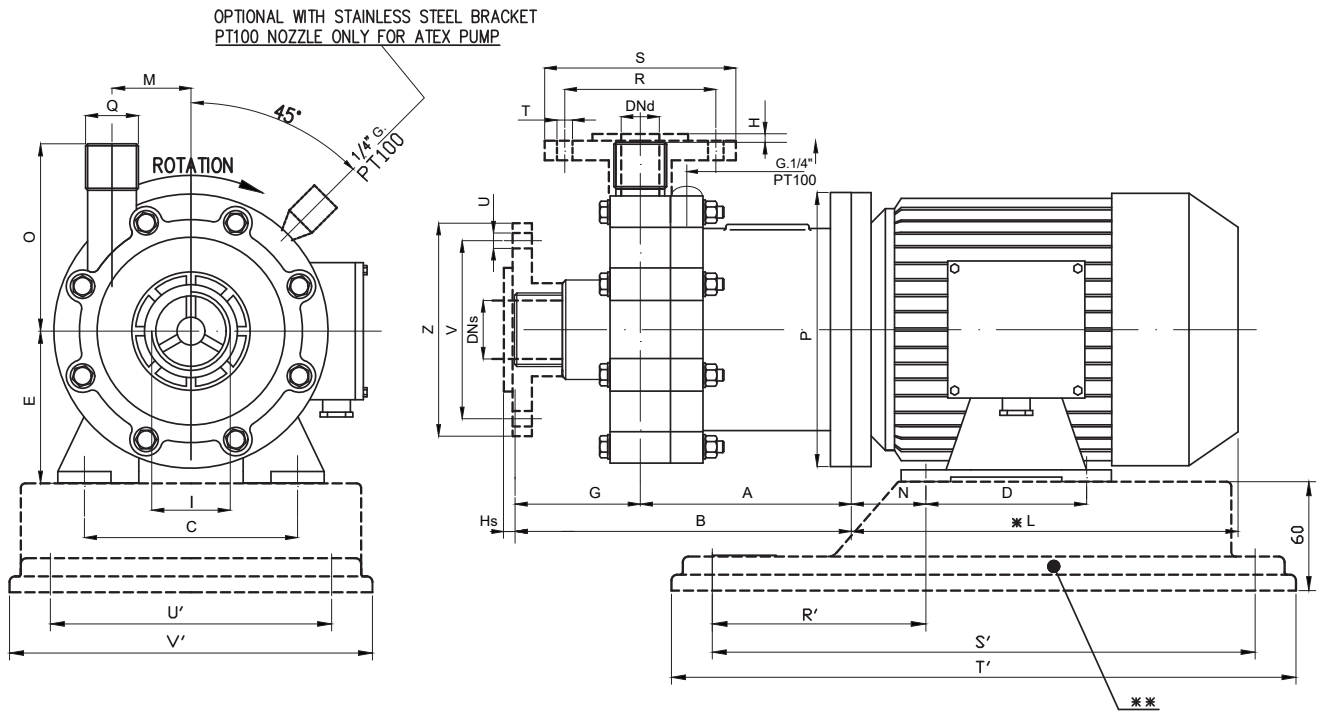

22

PUMP TYPE	FLANGES DIMENSIONS - mm -							
	R	S	T	U	V	Z	DN <sub>s</sub>	DN <sub>d</sub>
HTM 15 SS316	110	153	18	18	125	168	50	40
HTM 31 SS316	125	168	18	18	145	188	65	50

PUMP TYPE	MOTOR FLANGE B3 - B5	KW	DIMENSIONS - mm -														BASEPLATE DIMENSIONS - mm -					
			A	B	C	D	E	H <sub>s</sub>	G	H	I	-L	M	N	O	P	Q	R'	S'	T'	U'	V'
HTM 15 SS316	90 S	1.5	177	257	140	100	90	6	80	4	2" G. MALE	255	66	56	135	200	1" 1/2 G. MALE	132	302	350	157	205
HTM 31 SS316	90 L	2.2	175	266	140	125	90	6.5	91	6	2" 1/2 G. MALE	280	66	56	140	200	2" MALE	132	302	350	157	205

NOTE: DIRECTION OF ROTATION IS COUNTER CLOCKWISE AS SEEN WHEN FACING THE MOTOR.  
PUMPS AVAILABLE THREADED OR FLANGED.



**GEMMECOTTI SRL**

Via A. Volta 85/A  
20816 Ceriano Laghetto MB  
ITALY  
EUROPEAN UNION

Ph: +39 02.96460406  
Fax: +39 02.96469114

info@gemmecotti.com  
[www.gemmecotti.com](http://www.gemmecotti.com)

